



MACHINE TOOLS EQUIPMENTS

108

POS. STECHSTAHLHALTER **D**

PORTAUTENSILE DA TAGLIO "LAMA EMPIRE" **I**

TOOLHOLDER FOR CUTTING "EMPIRE" TYPE CUTTER **GB/USA**

PORTE-OUTIL POUR DECOUPAGE AVEC CUTTER "EMPIRE" **F**

PORTAUTIL DE CORTE "CUCHILLA EMPIRE" **S**

POS. 6a



TABELLA PAGINA SEGUENTE

TABLE NEXT PAGE

A RICHIESTA PER ALTRI TIPI DI MACCHINA - ON REQUEST FOR OTHER TYPES OF MACHINE

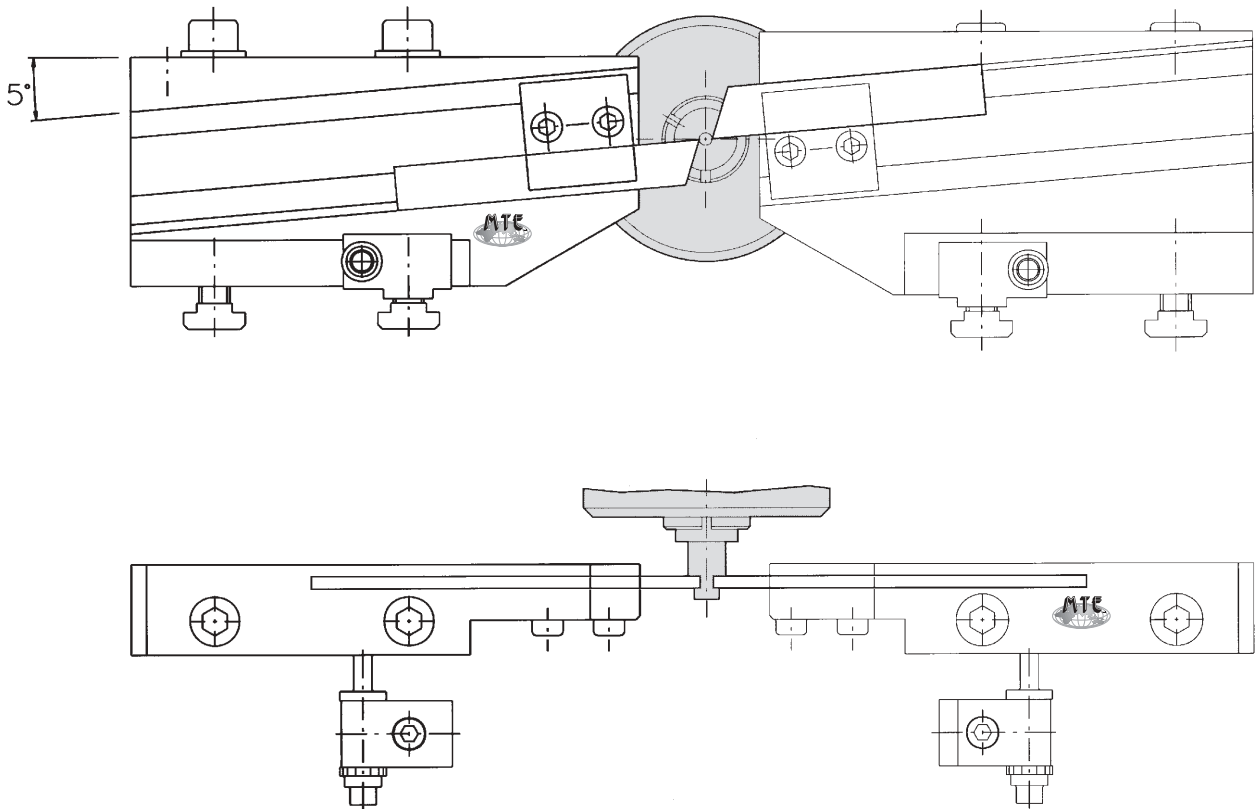

MACHINE TOOLS EQUIPMENTS

108

POS. STECHSTAHLHALTER **D**PORTAUTENSILE DA TAGLIO "LAMA EMPIRE" **I**TOOLHOLDER FOR CUTTING "EMPIRE" TYPE CUTTER **GB/USA**PORTE-OUTIL POUR DECOUPAGE AVEC CUTTER "EMPIRE" **F**PORTAUTIL DE CORTE "CUCHILLA EMPIRE" **S**

A RICHIESTA ALTRE ATTREZZATURE/FURTHER EQUIPMENTS ON REQUEST

ARTICOLO ARTICLE	MACCHINA MACHINE	LAMA EMPIRE EMPIRE CUTTER	POSIZIONE POSITION
---------------------	---------------------	------------------------------	-----------------------

WICKMAN

108.10.00	5/8"	1.6x12	6a
108.17.00	7/8" - 5 M	2.5x17	5a
108.19.00	1" 3/4 - 5 M	2.5x17	5a
108.20.00	1"	2.5x17	6a
108.29.00	32 - 8	2.5x17	6a
108.30.00	1" 3/4-3/8	2.5x17	6a
108.38.00	1" 3/8 - 5 M	2.5x17	5a
108.40.00	2" 1/4	3.2x22	6a
108.41.00	2" 5/8	3.2x22	6a
108.50.00	3" 1/2	3.2x22	6a
108.58.00	3" 1/4	3.2x22	6a

GILDEMEISTER

108.09.00	AS 12	1.6x12	6a
108.11.00	AS 16 - GM 16	1.6x12	6a
108.15.00	AS 20 - GS 20 - GM 20	1.6x12	6a
108.18.00	AS 22 - AS 25	2.5x17	6a
108.27.00	AA 32	2.5x17	6a
108.31.00	AS 32	2.5x17	6a
108.32.00	AS 40 - AS 48	2.5x17	6a
108.36.00	AA 48	2.5x17	6a
108.44.00	AS 55 - 67	3.2x22	6a
108.47.00	GM 35 - GM 42	2.5x17	6a
108.51.00	AA 67	3.2x22	6a
108.56.00	GM 32	2.5x17	6a
108.63.00	AS 63	3.2x22	6a
108.69.00	GS 50 - 51	3.2x22	6a
108.70.00	GM 26	2.5x17	6a
108.82.00	AS 82	3.2x22	6a
108.83.00	AS 100	3.2x22	6a

MORI SAY - EUROTURN

108.14.00	6/20	1.6x12	6a
108.24.00	6/25 - 6/32	2.5x17	6a
108.28.00	6/42	2.5x17	6a
108.53.00	8/32	2.5x17	6a
108.67.00	8/42	3.2x22	6a

INDEX

108.13.00	MS 25	1.6x12	6a
108.34.00	KS 25	2.5x17	6a
108.35.00	KS 42	2.5x17	6a
108.60.00	KS 18	2.5x17	6a
108.61.00	KS 32	2.5x17	6a
108.62.00	KS 50	2.5x17	6a

ARTICOLO ARTICLE	MACCHINA MACHINE	LAMA EMPIRE EMPIRE CUTTER	POSIZIONE POSITION
---------------------	---------------------	------------------------------	-----------------------

SCHÜTTE

108.08.00	SF 13	1.6x12	6a
108.21.00	SE 16 - SF 20	2.5x17	6a
108.22.00	SE 25	2.5x17	6a
108.23.00	SF 40 - SF 42	2.5x17	6a
108.33.00	SD 25 - SD 32	2.5x17	6a
108.42.00	SD 50	3.2x22	6a
108.43.00	SD 63 - SD 80	3.2x22	6a
108.46.00	SF 26 - SF 32	2.5x17	6a
108.48.00	AD 40	2.5x17	6a
108.49.00	SF 51	2.5x17	6a
108.54.00	SF 67	3.2x22	6a
108.55.00	SF 26 L	2.5x17	6a
108.73.00	AG 20	1.6x12	6a
108.81.00	SF 81	3.2x22	6a
108.84.00	AF 42/51	3.2x22	6a
108.85.00	AF 26/32	2.5x17	6a

PITTLER

108.25.00	PRB 8/25	2.5x17	6a
108.26.00	PRB 8/32 - PRC 6/32	2.5x17	6a
108.37.00	DAM 6/50	3.2x22	6a
108.39.00	DAM 8/32	2.5x17	6a
108.45.00	PRB 6/50 - PRC 6/50	2.5x17	6a
108.52.00	PRB 36/6	2.5x17	6a
108.64.00	PRC 36/6	2.5x17	6a
108.65.00	DAM 6/32	2.5x17	6a
108.71.00	PRC 100/4-72/6-50/8	2.5x17	6a

BSA

108.59.00	2"	2.5x17	6a
108.68.00	2" 1/4	2.5x17	6a

ACME GRIDLEY

108.12.00	16 m/m	2.5x17	6a
108.57.00	1" 1/4 - 6 M	2.5x17	6a
108.74.00	1" 5/8	2.5x17	6a

TOS / AN

108.88.00	6/25 A	2.5x17	6a
108.89.00	6/40 A	2.5x17	6a
108.90.00	6/63 A	2.5x17	6a

A RICHIESTA PER ALTRI TIPI DI MACCHINA - ON REQUEST FOR OTHER TYPES OF MACHINE