



MACHINE TOOLS EQUIPMENTS

103

JUSTIERBARER FLACHSTAHLWERKZEUGHALTER RECHTS **D**

PORTAUTENSILE PIATTO UNIVERSALE **I**

PLATFORM TOOLHOLDER **GB/USA**

PORTE-OUTIL PLAT UNIVERSEL **F**

PORTAUTIL PLANO UNIVERSAL **S**

POS. 2-3-5



TABELLA PAGINA SEGUENTE

TABLE NEXT PAGE

A RICHIESTA PER ALTRI TIPI DI MACCHINA - ON REQUEST FOR OTHER TYPES OF MACHINE

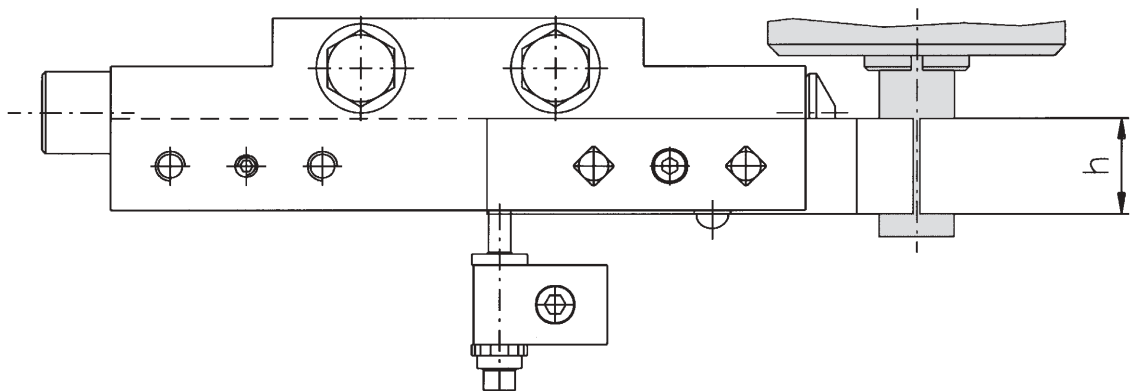
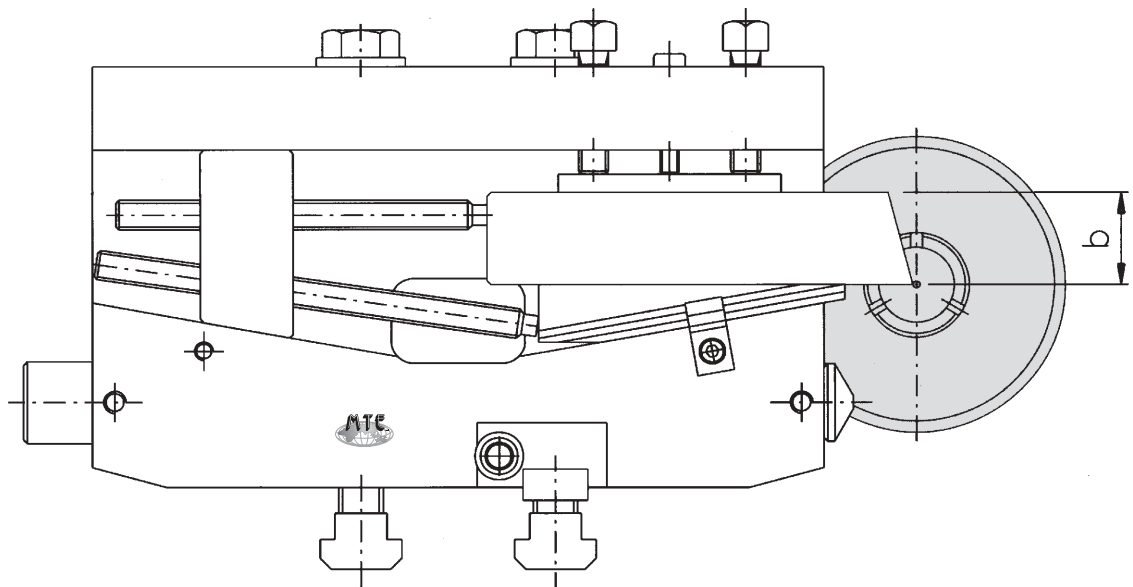

MACHINE TOOLS EQUIPMENTS

103

JUSTIERBARER FLACHSTAHLWERKZEUGHALTER RECHTS

D

PORTAUTENSILE PIATTO UNIVERSALE

I

PLATFORM TOOLHOLDER

GB/USA

PORTE-OUTIL PLAT UNIVERSEL

F

PORTAUTIL PLANO UNIVERSAL

S

A RICHIESTA ALTRE ATTREZZATURE/FURTHER EQUIPMENTS ON REQUEST

ARTICOLO ARTICLE	MACCHINA MACHINE
---------------------	---------------------

WICKMAN

103.10.00	5/8"
103.17.00	7/8" - 5 M
103.19.00	1" 3/4 - 5 M
103.20.00	1"
103.29.00	32 - 8
103.30.00	1" 3/4-3/8
103.38.00	1" 3/8 - 5 M
103.40.00	2" 1/4
103.41.00	2" 5/8
103.50.00	3" 1/2
103.58.00	3" 1/4

GILDEMEISTER

103.09.00	AS 12
103.11.00	AS 16 - GM 16
103.15.00	AS 20 - GS 20 - GM 20
103.18.00	AS 22 - AS 25
103.27.00	AA 32
103.31.00	AS 32
103.32.00	AS 40 - AS 48
103.36.00	AA 48
103.44.00	AS 55 - 67
103.47.00	GM 35 - GM 42
103.51.00	AA 67
103.56.00	GM 32
103.63.00	AS 63
103.69.00	GS 50 - 51
103.70.00	GM 26
103.82.00	AS 82
103.83.00	AS 100

MORI SAY - EUROTURN

103.14.00	6/20
103.24.00	6/25 - 6/32
103.28.00	6/42
103.53.00	8/32
103.67.00	8/42

INDEX

103.13.00	MS 25
103.34.00	KS 25
103.35.00	KS 42
103.60.00	KS 18
103.61.00	KS 32
103.62.00	KS 50

ARTICOLO ARTICLE	MACCHINA MACHINE
---------------------	---------------------

SCHÜTTE

103.08.00	SF 13
103.21.00	SE 16 - SF 20
103.22.00	SE 25
103.23.00	SF 40 - SF 42
103.33.00	SD 25 - SD 32
103.42.00	SD 50
103.43.00	SD 63 - SD 80
103.46.00	SF 26 - SF 32
103.48.00	AD 40
103.49.00	SF 51
103.54.00	SF 67
103.55.00	SF 26 L
103.73.00	AG 20
103.81.00	SF 81
103.84.00	AF 42/51
103.85.00	AF 26/32

PITTLER

103.25.00	PRB 8/25
103.26.00	PRB 8/32 - PRC 6/32
103.37.00	DAM 6/50
103.39.00	DAM 8/32
103.45.00	PRB 6/50 - PRC 6/50
103.52.00	PRB 36/6
103.64.00	PRC 36/6
103.65.00	DAM 6/32
103.71.00	PRC 100/4-72/6-50/8

BSA

103.59.00	2"
103.68.00	2" 1/4

ACME GRIDLEY

103.12.00	16 m/m
103.57.00	1" 1/4 - 6 M
103.74.00	1" 5/8

TOS / AN

103.88.00	6/25 A
103.89.00	6/40 A
103.90.00	6/63 A

NEW BRITAIN

103.91.00	52
103.96.00	62

TOOL (bxh): 12x12 - 16x16 - 18x18 - 20x20 - 25x25